

CITY OF WILLIAMSPORT, PA RESOLUTION

RESOLUTION # 8830

DATE 12-13-18

TITLE

Resolution to Approve A Pledge Agreement to Establish the Stephen Poorman Legacy
Society

BE IT HEREBY RESOVLED BY THE CITY COUNCIL OF THE CITY OF WILLIAMSPORT that the Agreement attached hereto, and between the City of Williamsport and Stephen P. Poorman and Pamela Fisher Poorman is hereby approved, and the appropriate City Officials are hereby authorized to execute the Agreement.

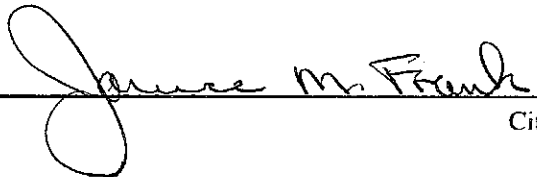

City Clerk

Approved

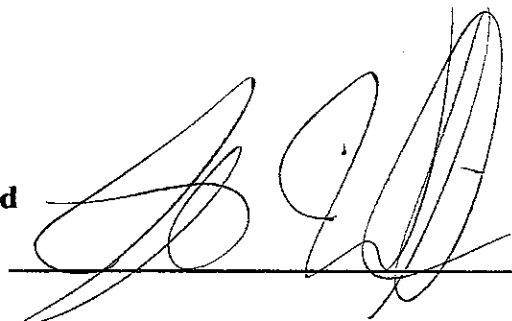

President

**PLEDGE AGREEMENT
TO ESTABLISH THE
STEPHEN POORMAN LEGACY SOCIETY FOR
THE CITY OF WILLIAMSPORT
PARKS AND RECREATION PROJECTS**

This Pledge Agreement ("Agreement"), dated this _____ day of December, 2018, by and between the City of Williamsport ("City"), with its address at 245 West Fourth Street, Williamsport, Lycoming County, Pennsylvania, and Stephen P. Poorman and Pamela Fisher Poorman ("Donors"), with their business office at 143-147 East Main Street, Suite 2D, Lock Haven, Clinton County, Pennsylvania, shall provide for a charitable contribution ("Gift") to support the needs of the parks and recreation facilities ("Parks"), while commensurately encouraging others to become future donors.

Funding Guidelines

The Donors are establishing its Gift by making a Twenty-Seven Thousand (\$27,000.00) Dollar cash obligation ("Cash Obligation"); to be paid on or before December 31, 2018. In addition, Donors herein pledge an estimated Two Hundred Thirty-Eight Thousand Six Hundred Seventy-Five (\$238,675.00) Dollars of residual estate and/or trust funds ("Legacy Pledge") to be paid from the Donor's Estate and/or Trust upon the death of both Donors; for a total commitment of Two Hundred Sixty-Five Thousand Six Hundred Seventy-Five (\$265,675.00) Dollars ("Gift"), under any future Gift Acceptance Policy the City might opt to create. The Legacy Pledge will in part fund a legacy society ("Legacy Society") to encourage future donors to privately support Parks and to pay for immediate needs as hereinafter set forth. The Cash Obligation check shall be made payable to the City Treasurer and sent to the Office of the Mayor for proper recording and depository transmitting.

Verification and Confirmation of Legacy Pledge of Residual Estate and/or Trust Funds

Agents of City, and/or representatives of its City Council, or other appointed City officials, shall be privy to any or all financial documents to verify that Donor's estimated Legacy Pledge is reasonable, accurate and *irrevocable*. On or before December 31, 2018, Donors shall include the Legacy Pledge the amount of approximately Two Hundred Thirty-Eight Thousand Six Hundred Seventy-Five (\$238,675.00) Dollars, to be binding on the Donor's agents, guardians, executors, trustees, administrators, and assigns, and the Legacy Society in their Wills and/or Trusts and shall also provide City agents full access to those estate documents. Until the Legacy Pledge is satisfied, Donors, or their agents, guardians, executors, trustees, administrators, and assigns, upon request of Agents of the City, and/or representatives of its City Council, or other appointed City Officials, agree to provide any financial documents or estate planning documents to verify the continued existence of the *irrevocable* Legacy Pledge.

Restricted Use of Proceeds

Both the Cash Obligation and the Legacy Pledge may only be used for (1) renovation of a restroom at the former East End Pool at Shaw Place Park on Sheridan Street to be

converted into a family recreational complex (2) a pavilion to be constructed at Splash Cove on West Fourth Street (3) permanent shading improvements at Brandon Park or (4) Other Parks and Recreation Projects to be determined by the City Administration with approval by City Council. An example of the Splash Cove pavilion is shown on Exhibit "B", attached hereto. The proceeds may not be used for any payroll or administrative expenses.

Reserve of Proceeds

The City shall reserve One Hundred Twenty Five Thousand (\$125,000.00) Dollars of the Legacy Pledge to create the Legacy Society, in perpetuity, as hereinafter set forth.

Fund Administration

The Gift, and any future contributions to City, are made absolutely to City, which is an organization that is qualified to receive deductible charitable contributions as described in Section 170 of the Internal Revenue Code and earmarked only for parks and recreation projects. Gifts to the City's Legacy Society fund shall constitute an endowment corpus, which will be held in perpetuity and invested, maintained, administered and distributed by City in accordance with its governance policies and applicable present or future Pennsylvania laws, to support the purpose(s) it may define with an emphasis on parks and recreation. Fund distributions may include, but are not limited to, interest, dividends, market appreciation, gains, a portion of the endowment corpus or other income.

Stephen Poorman shall serve as Donor's principal liaison. In his stead, Donor's gifting will be administered by Donor's appointed Trustees including Pamela Fisher Poorman, Woodlands Bank, R. Thompson Rosamilia, Esquire and/or Micah T. Clausen; the City shall receive and distribute all funds exclusively for parks and recreation projects. City designates its Mayor or the Director of the Department of Recreation as its principal liaison.

Gift Recognition

In recognition of the impact this Gift should have on the future of City parks and recreational facilities, and to encourage similar giving, this Gift will be recognized by signage similar to that shown on Exhibit "C", attached hereto, acceptable in size and style to City and Donors. Donors' Cash Obligation Gift includes monies in the amount of Two Thousand Dollars (\$2,000.00) to City toward the cost of the aforementioned signage. This recognition signage, after required sign permits are issued, shall be erected along West Fourth Street at the entrance to Memorial Park and a second recognition sign inside Brandon Park if funds are utilized to create a permanent shading pavilion. An example of the signage is attached hereto and marked Exhibit "D". The City shall require that Lamar Advertising of Williamsport remove an existing billboard at the entrance to Memorial Park within twelve (12) months after the date of this Agreement. Donors have relinquished their naming rights on the Splash Cove buildings and Splash Cove pavilion in order to allow naming opportunities for future donors. If recognition signage is stolen or removed, it shall be replaced with a like size, kind and quality by City at its sole and exclusive expense.

Upon the death of both Donors, and the completion of the administration of Donor's Estate and/or Trust, should the Legacy Pledge not be satisfied in the approximate amount of Two Hundred Thirty-Eight Thousand Six Hundred Seventy-Five (\$238,675.00) Dollars, City, in its sole discretion, may amend or replace the gift name recognition with gift name recognition of that of another Legacy Society donor, other donor, or otherwise.

Any news media announcement of the creation of the Gift or Legacy Society shall be made on or before December 31, 2018 at the Office of the Mayor of Williamsport, with a formal on-site dedication in 2019.

Legacy Guidelines

The Legacy Society fund shall be administered in accordance with the following guidelines:

1. The Legacy Society shall be known as the Stephen Poorman Legacy Society and noted as such on all solicitations, marketing, documents and as a bi-line under future donor's names.
2. The number, amount of gifts and recognition for other donors shall solely be determined by City in its sole and absolute discretion. The recognition of other donors who follow may be granted naming rights to any parks or recreation facilities within the City.
3. The term of the Legacy Society shall be for perpetuity.
4. Legacy Society funds in excess of \$125,000.00 provided by Donor do not need to be considered an invested endowment, but instead, the City may access all or part of the funds as they become available. In no event shall the City expand the original principle of at least \$125,000 legacy funds.

Legacy Fund Management

City shall administer the Legacy Society funds and it shall make any or all decisions relating to asset allocation, without limitation.

Irrevocable Funding Requirements

The estimated residual estate funds ("Legacy Funds") to create the Legacy Society shall be funded upon the death of both Donor(s) Stephen P. Poorman and Pamela Fisher Poorman. Donors shall designate the Legacy Funds in the approximate amount of Two Hundred Thirty-Eight Thousand Six Hundred Seventy-Five (\$238,675.00) Dollars and the Legacy Society fund in their Will and/or Trust to be *irrevocable* and binding upon the Donor's agents, guardians, executors, trustees, administrators, and assigns.

Termination of Gift and Pledge

If this Agreement is not executed on or before December 17, 2018, it shall expire and neither party referenced herein shall have any further obligations or responsibilities.

Conflict with Law

If any provision of this Agreement is found to conflict with or violate any Federal or state law or regulation, then that provision will be modified to bring the Agreement into compliance with the conflicting law or regulation. However, all other provisions will continue to be administered in accordance with Donors' intent and commitment.

Notices

All notices, demands, requests, offers, consents, acceptances and other communications which may be required or otherwise given pursuant to this Agreement shall be in writing, sent by United States Certified Mail, Return Receipt Requested, postage prepaid, or an electronic submission provided the latter means can verify proper receipt by the intended recipient, addressed as follows:

For the Donor: Stephen P. Poorman
143-147 East Main Street, Suite 2D
Lock Haven, Pennsylvania 17745
Telephone: (570) 748-7000, Option 2
Telecopy: (570) 748-7700
Email: steve@poormangroup.com

In Donor's stead: Sarah A. McCracken
Administrative Coordinator
Administration of Estate and Trust of
Stephen and Pamela Fisher Poorman
143-147 East Main Street, Suite 2D
Lock Haven, Pennsylvania 17745
Telephone: (570) 748-7000, Option 2
Telecopy: (570) 748-7700
Email: sarah@poormangroup.com

For the City: Attention: Director
Department of Parks & Recreation
CITY OF WILLIAMSPORT
245 West Fourth Street
Williamsport, Pennsylvania 17701
Telephone: (570) 327-7510

With a Copy to: Attention: Mayor
CITY OF WILLIAMSPORT
245 West Fourth Street
Williamsport, Pennsylvania 17701
Telephone: (570) 327-7566

SPLASH COVE - MEMORIAL PARK

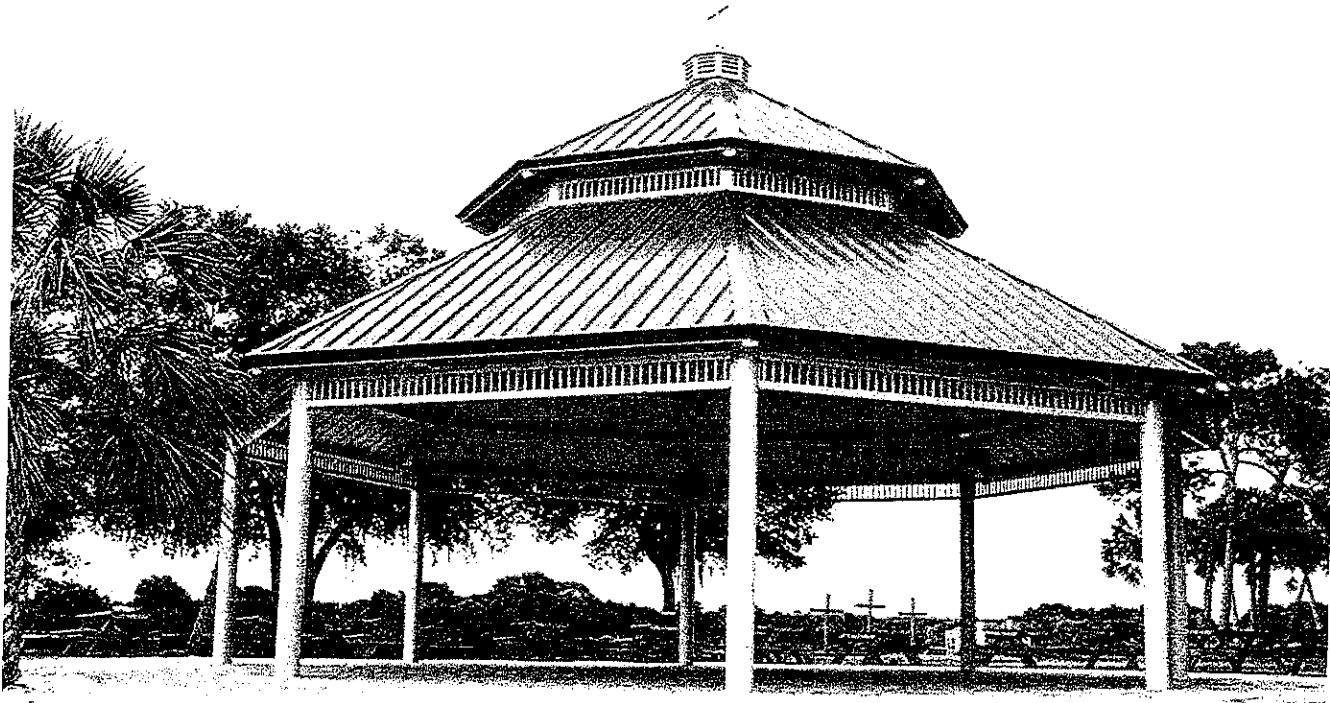

EXHIBIT
"B"

tabbles

PRELIMINARY

Elements

Litchfield

All quotation drawings are preliminary only,
not to be used for installation of any kind.

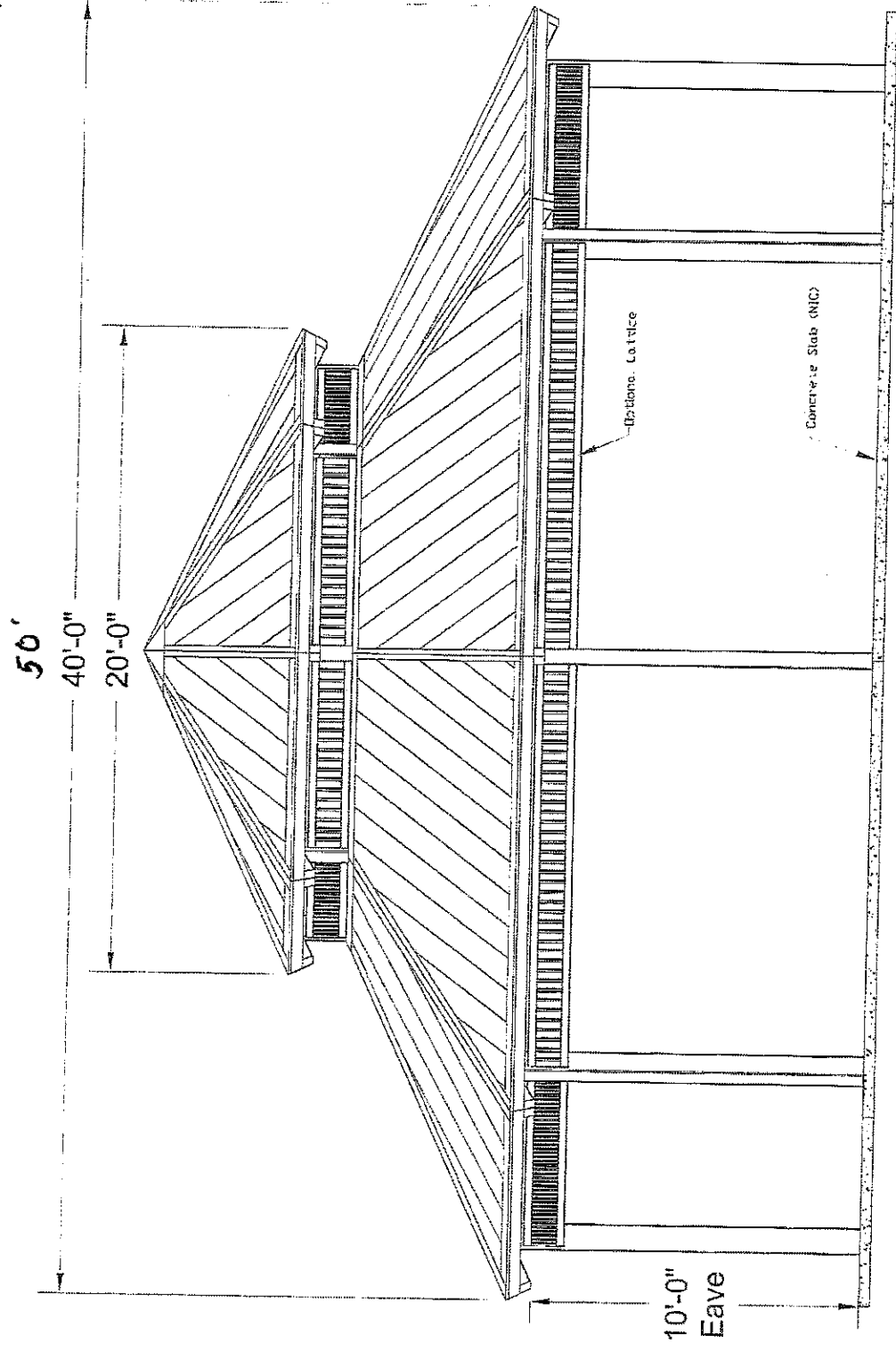

MODEL: 40' (AS) Octagonal Duo-Top Structure
 SHEET: 1 QUOTE #: L7157WD
 Ph: 678 838 5700
 FX: 678 838 5732



TITLE: Elevation
 DRAWN BY: M.R.I. DATE: 09/26/2012 206 Adamson Ind Blvd
 Carrollton, GA 30117

Landscape

Litchfield

Elements

PRELIMINARY

All quotation drawings are preliminary only,
not to be used for installation of any kind.

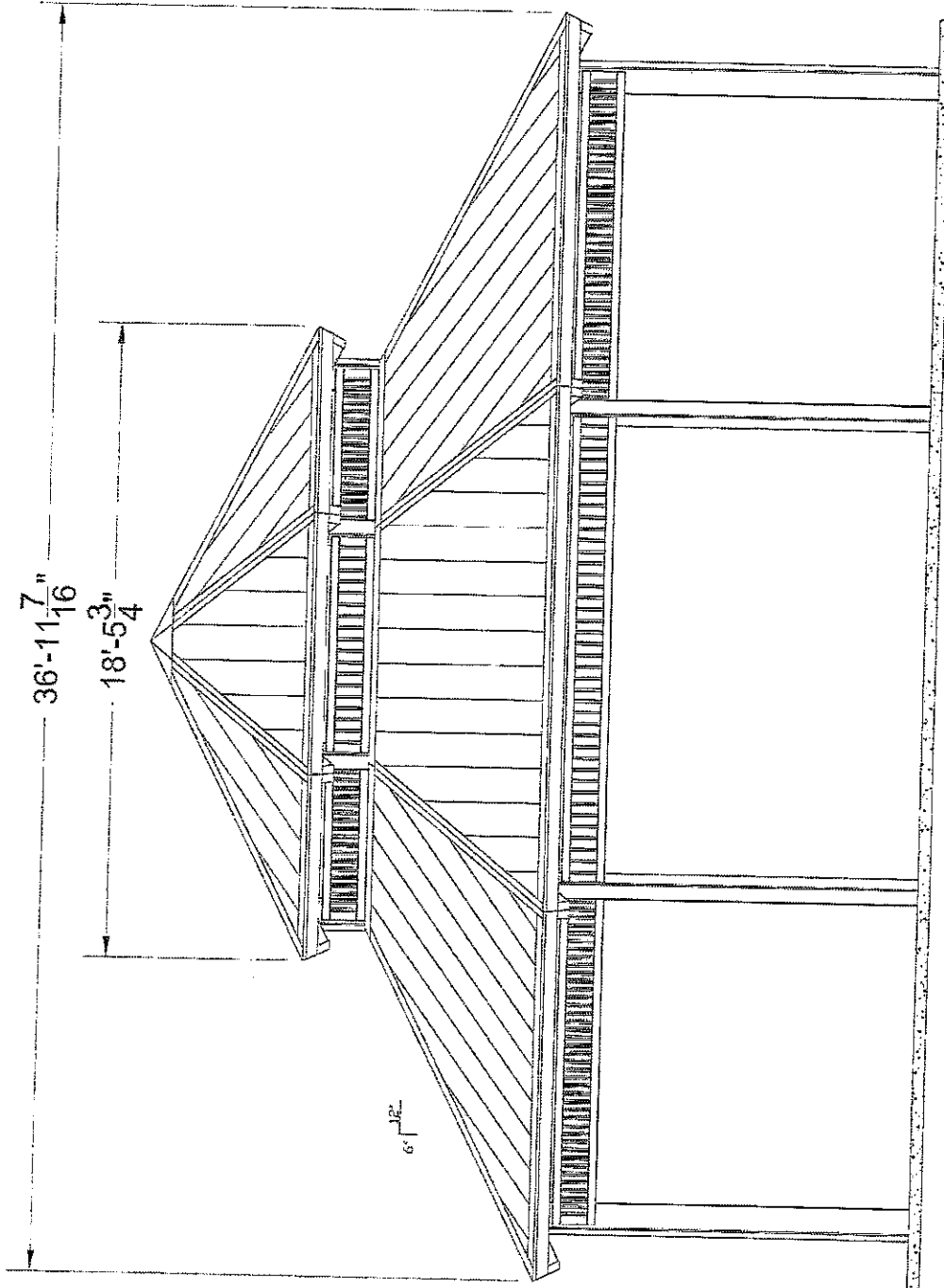

TITLE: Elevation

DRAWN BY: M.R.I.

DATE: 09/26/2012 206 Adamson, Ind Blvd
Carrollton, GA 30117

MODEL: 40' (AS) Octagonal Duo-Top Structure

Ph: 678 839 5700
Fk: 678 839 5732

SHEET: 2

QUOTE #: L7157WD



Landscape

PRELIMINARY

Elements

Litchfield

All quotation drawings are preliminary only,
not to be used for installation of any kind.

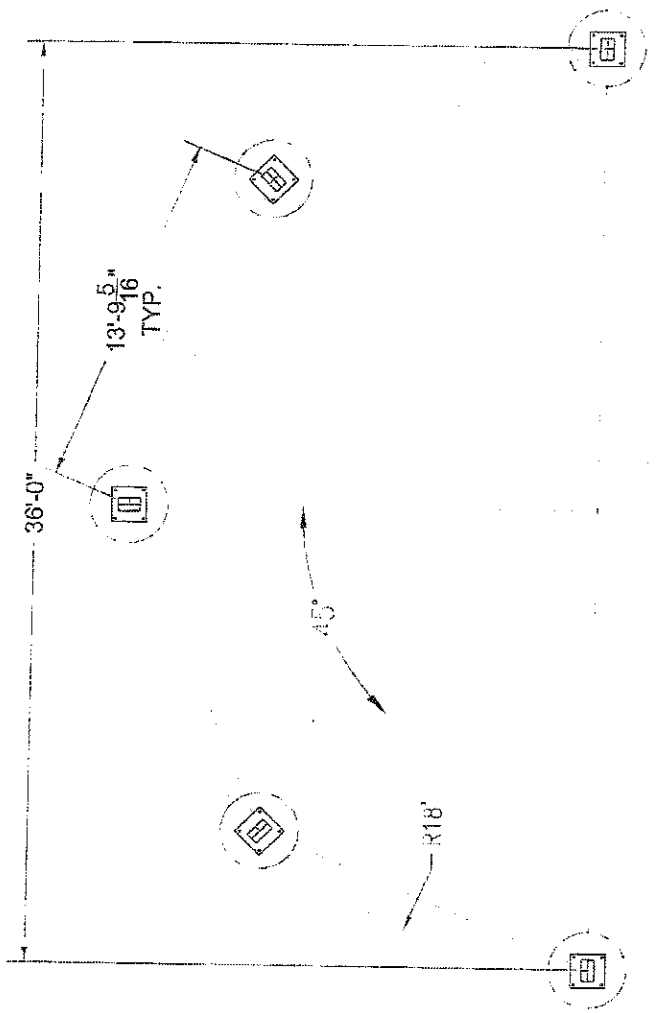

MODEL: 40' (AS) Octagonal Duo-Top Structure

QUOTE #: L7157WD

SHEET: 3

Ph: 678 839 5700
Fk: 678 839 5732

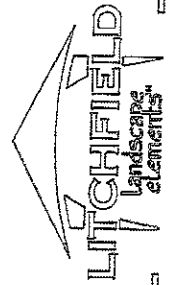

TITLE: Ground Plan

DRAWN BY: M.R.I. DATE: 09/26/2012 206 Adamson Ind Blvd
Carrollton, GA 30117

Landscape

All quotation drawings are preliminary only, not to be used for installation of any kind.

***DESIGN NOTE:**

All foundation design information should be considered as preliminary only. A local soils engineer shall be retained to design the foundation according to local conditions and codes. Final design of the footing/foundation is the responsibility of the general contractor/owner.

PRELIMINARY

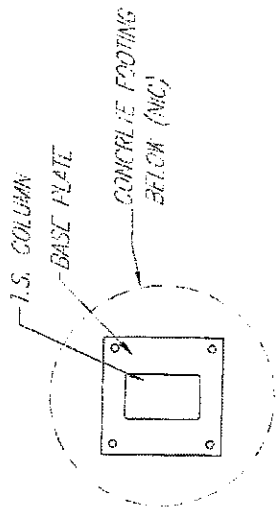

COLUMN BASE PLATE PLAN

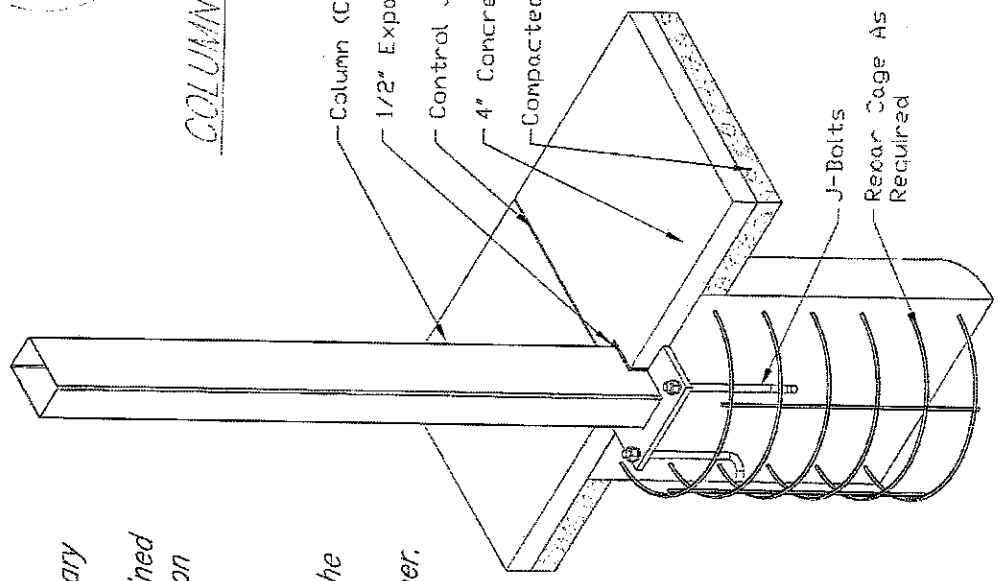

Elements

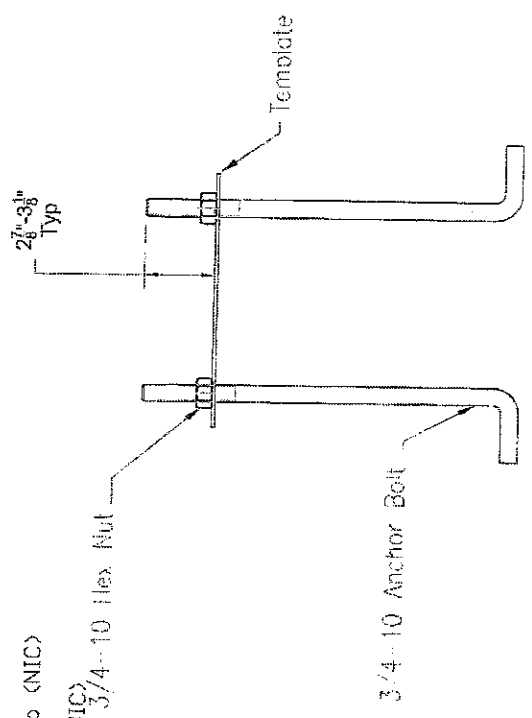

ANCHOR BOLT TEMPLATE ASSEMBLY

TITLE: Column Detail

DRAWN BY: M.R.I. DATE: 09/26/2012 206 Adamson Ind Blvd Carrollton, GA 30117

MODEL: 40' (AS) Octagonal Duo-Top Structure

Ph: 678 839 5700 Fx: 678 839 5732

SHEET: 4

QUOTE #: L7157WD

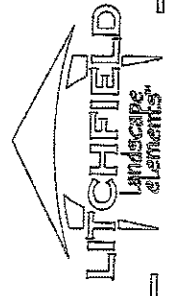

All quotation drawings are preliminary only, not to be used for installation of any kind.

Material Specifications and Notes:

1. All structural steel tubing shall be ASTM A-500 Grade B.
 2. All other steel (plates, gussets, etc.) shall be ASTM A-36.
 3. All welding is to be done in accordance with latest AWS standards. All welds are to develop full strength of component parts. (E7081 Electrodes)
 4. All bolts to be ASTM A-325 & threaded rod to be ASTM B-7.
 5. All fabricated steel & structural tubes to be sand blasted to a white condition
- Electrostatic Special Epoxy TGIC Primer Applied - 3 mils.
 Electrostatic Epoxy TGIC "Top Coat" Powder Coat Applied - 3 mils.
 Final cure of coating at 450 degrees for 30 to 45 minutes.

Roofing Materials- 24 Ga. 50 Ksi 1 1/4" Dp x 36" Wide R-Panel Pre-Cut Metal Roofing.

ERECTION NOTES:

All members must be properly braced until the complete structural system has been constructed.

This building has been designed as a free standing, open structure. If walls are to be added, or if the building is to adjoin another structure, or if other modifications are to be made, the structure must be reengineered prior to these modifications.

THIS DOCUMENT CONTAINS PROPRIETARY INFORMATION AND IS NOT TO BE REPRODUCED WITHOUT THE WRITTEN PERMISSION FROM LITCHFIELD INDUSTRIES, INC. AND/OR IS NOT TO BE USED IN ANY MANNER DETRIMENTAL TO THE INTEREST OF LITCHFIELD INDUSTRIES, INC.

N.I.C. = NOT IN CONTRACT

TITLE: General Notes

DRAWN BY: M.R.I. DATE: 09/26/2012 206 Adkinson Ind Blvd
Carrollton, GA 30117

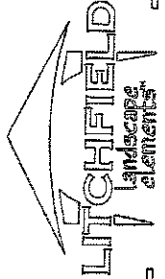

MODEL: 40' (AS) Octagonal Duo-Top Structure

Ph: 678 839 5700
Fk: 678 839 5732

SHEET: 5

QUOTE #: L7157WD

ENTRANCE TO MEMORIAL PARK



LOGO AS IS

WHITE BACKGROUND

STEPHEN POORMAN TRUST

WHITE
LIGHT GREY BACKGROUND

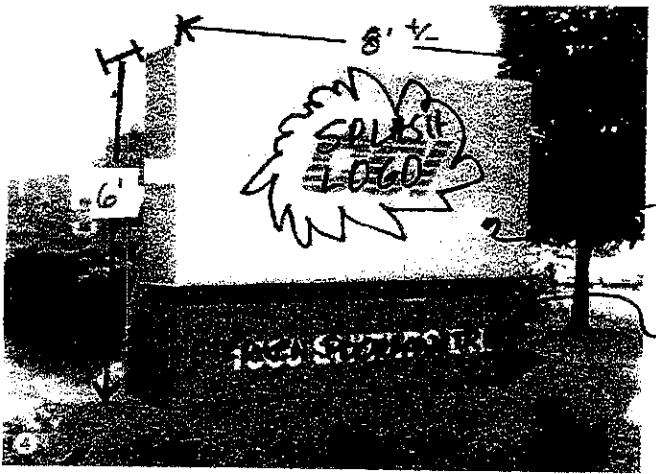

INTERNALLY ILLUMINATED ENTRANCE SIGN



1744 W 4th St

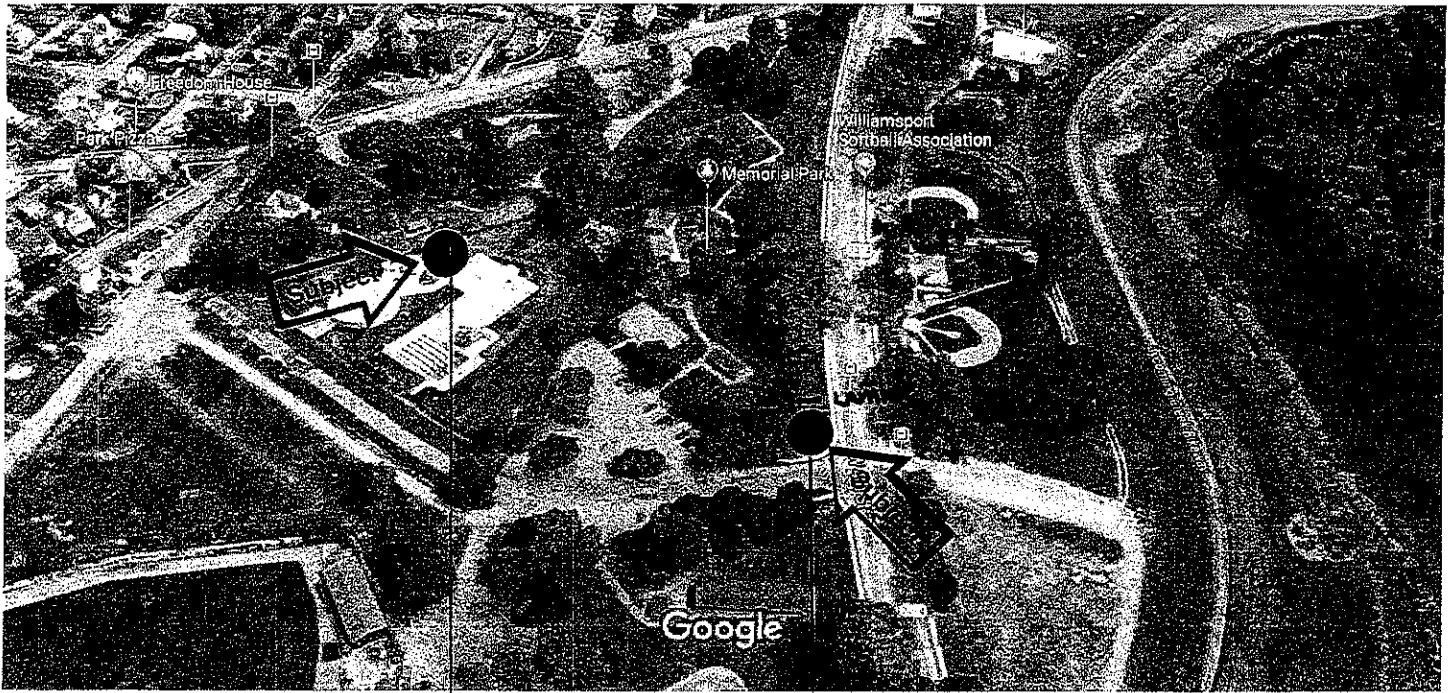

Location Map

APPROXIMATE
LOCATION OF
NEW ENTRANCE
SIGNAGE

APPROXIMATE
LOCATION OF
PAVILION

BRANDON PARK SHADING PAVILION

EXAMPLE ONLY

24"

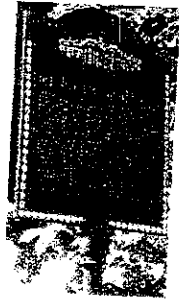

36"



THE STEPHEN POORMAN TRUST

Mr. Poorman, along with The Clinton County Historical Society created this display of vintage railway cars which date back to 1947.

Born in Castanea, Mr. Poorman restored many historically significant buildings:

- c1827 Thomas Smith House
built by Clinton County's first Treasurer
- c1840 Jacob Grafius House
retail store on Lock Haven's riverbank
- c1871 Lock Haven Market House
area's first provisions center
- c1877 Frederick Building
Mayor Heffner's corner drug store
- c1883 Simon Building
built by area's first female businesswoman

Other Poorman buildings restored and placed on the National Register of Historic Places include: The Hart, Firth, Grand Central, Williamsport Opera and Pittsburgh Mercantile Bank buildings.

Cast Aluminum

